

Metacone™ & HK™



Metalastik® type Metacone™

Novibra® type HK™

A range of mountings designed for high load capacity with relatively large static deflections. The high loading for a given size is achieved by utilising the rubber to best advantage in shear and compression. Normally, mountings are assembled with overload and rebound washers to control and limit movement of the suspended equipment under shock loads. Centre fixing bolts should be torque tightened to the recommended values.

Applications include suspensions for:

- ▼ Off-road and road vehicle engines
- ▼ Vehicle Cabs
- ▼ Oil Tanks/Tankers
- ▼ Mobile applications

Drawing no. Metacone™	Part no.	Max vert. Load (Kg)	Weight (Kg)
17-0189	10-00365	145	0,28
17-0189	10-00367	400	0,28
17-0241	10-00374	62	0,18
17-0241	10-00375	122	0,18
17-0248	10-00379	95	0,19
17-0248	10-00380	190	0,19
17-0277	10-00385	125	0,56
17-0277	10-00387	230	0,56
17-0379	10-00402	35	0,12
17-0379	10-00404	70	0,12
17-0341	10-00394	160	0,54
17-0341	10-00395	300	0,54
17-0341	10-00396	430	0,54
17-0311	10-00391	125	0,58
17-0311	10-00392	220	0,58
17-1691	10-00566	72	0,44
17-1691	10-00567	144	0,44
HK			
HK60-40	10-01119	90	0,24
HK60-50	10-01122	115	0,24
HK60-60	10-01120	180	0,24
HK60-70	10-01121	250	0,24

Features

A compact fail safe design, available for a wide range of loadings with in some cases alternative fixings.

Cutouts in rubber section on various sizes provide different vertical/horizontal stiffness ratios.

Most sizes can be supplied complete with overload and rebound washers.

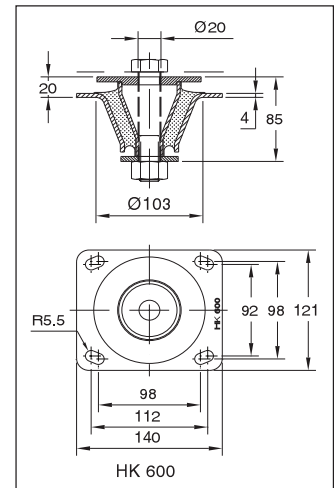
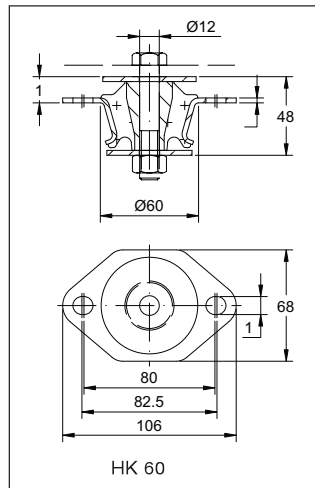
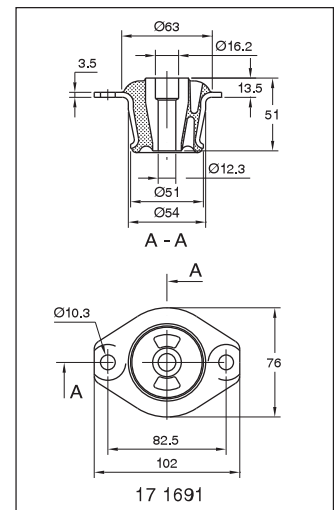
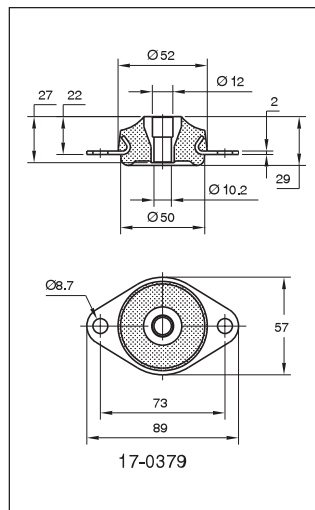
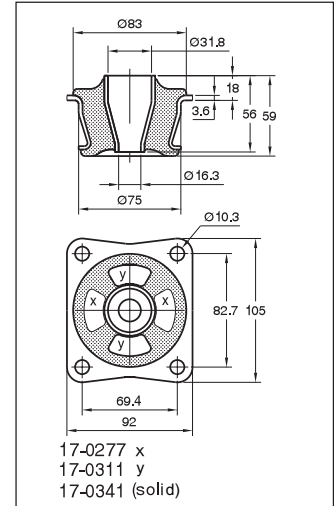
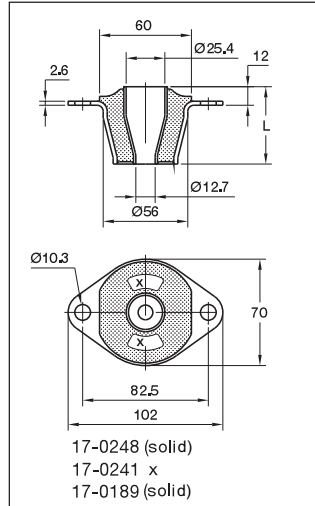

Note: The natural frequencies and degrees of isolation are based on dynamic characteristics of the mountings.

Load per mounting (kg)

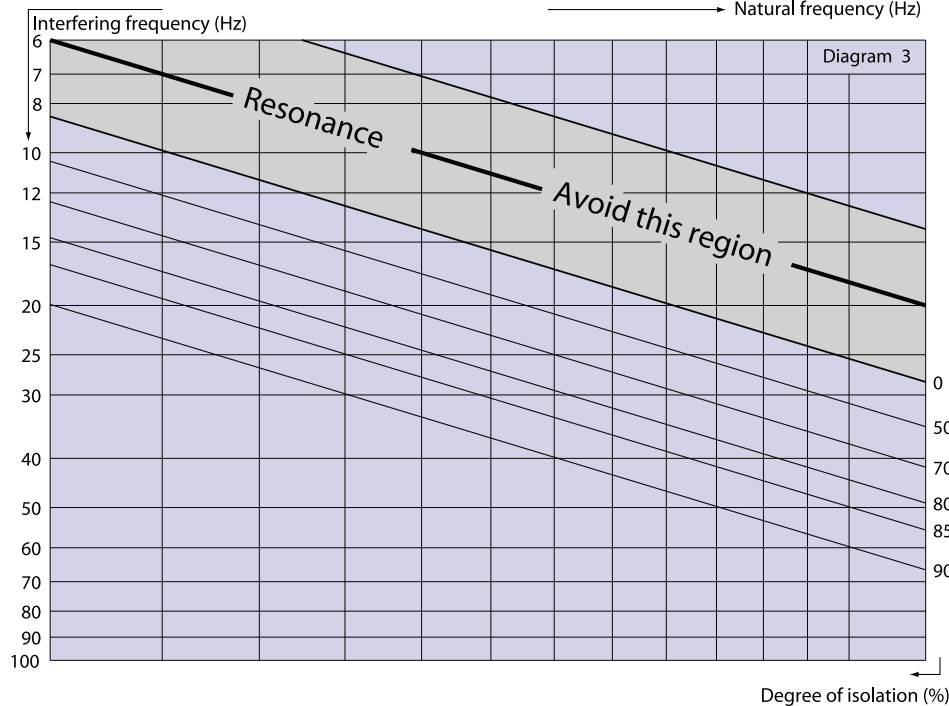
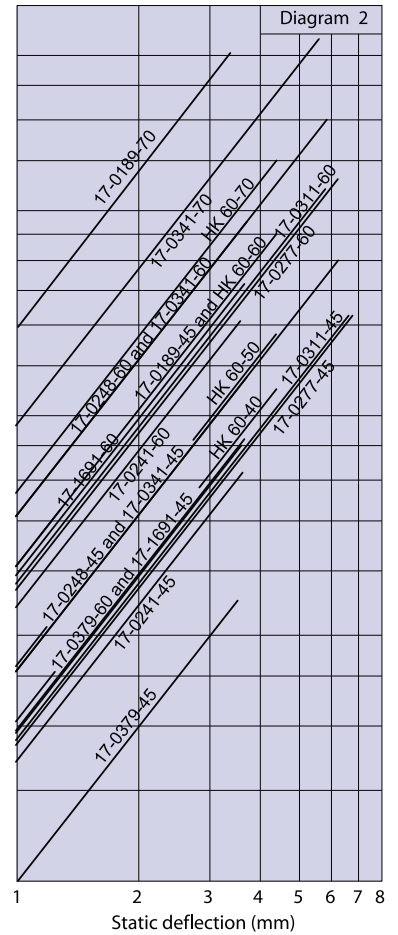
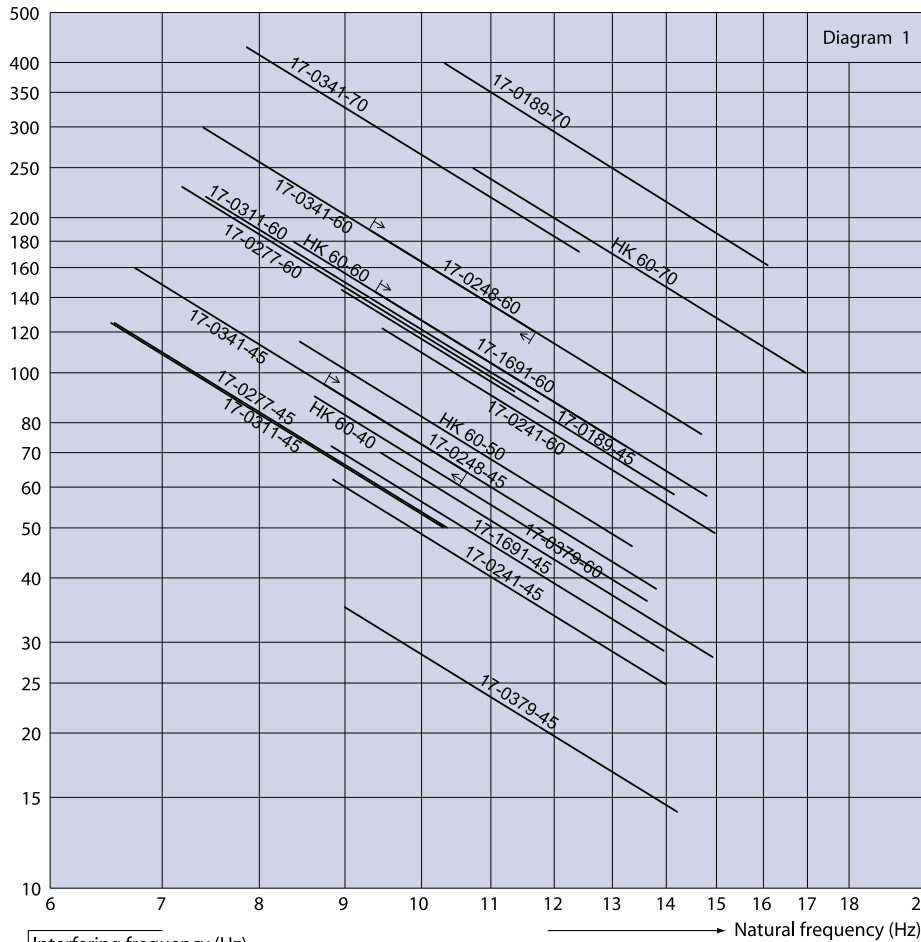

To select correct mounting, following data are needed:
 1) Load per mounting (kg)
 2) Interfering frequency (Hz)
 (Hz = rpm / 60)
 Select correct load line in diagram 1 and correct interference line in diagram 3. The load line intersects with required type of mounting.
 Connect this intersection point vertically down to the interference line in diagram 3. Here, on the sloping curve, the isolation degree is indicated.
 For static deflection, see diagram 2.

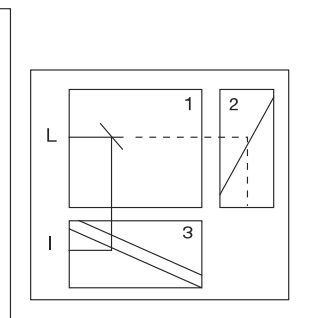

Metacone™ & HK™

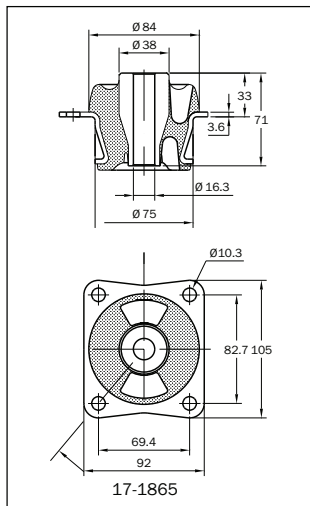
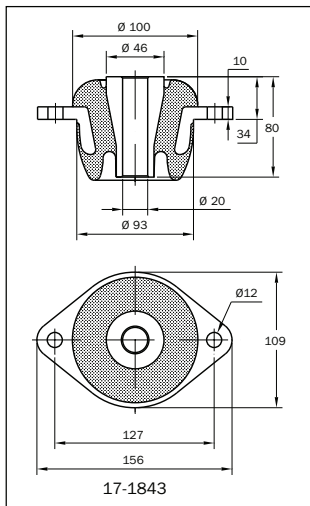
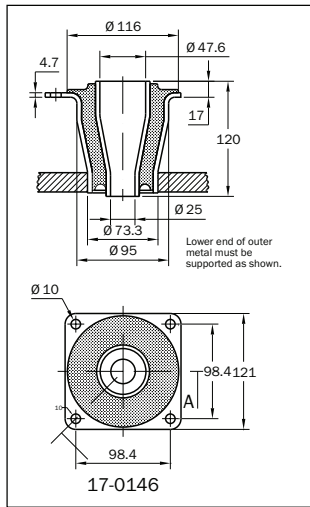
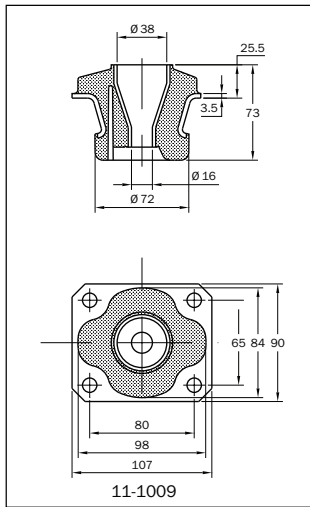

Drawing no. Metacone™	Part no.	Max vert. Load (Kg)	Weight (Kg)
11-1009	10-00192	140	0,59
11-1009	10-00193	200	0,59
17-0391	10-00411	290	1,1
17-0391	10-00414	500	1,1
17-0391	10-00415	610	1,1
17-0566	10-00433	200	0,82
17-0566	10-00434	380	0,82
17-0566	10-00435	525	0,82
17-1227	10-00459	560	1,1
17-1227	10-00460	1000	1,1
17-1550	20-02522	720	4,4
17-1550	20-02523	1250	4,4
17-1843	20-02529	320	1,7
17-1843	20-02530	600	1,7
17-1865	10-00615	180	0,86
17-0146	10-00360	950	2
17-0146	10-00361	1700	2
HK™			
HK600-40	10-00190	940	1,0
HK600-60	10-00191	1700	1,0



Metacone™ & HK™

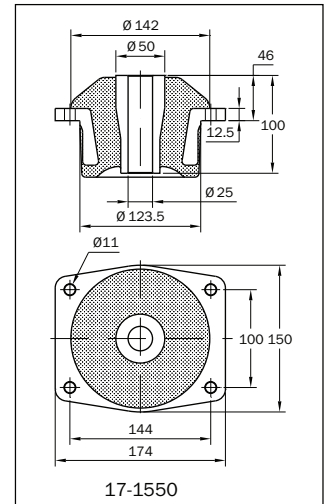
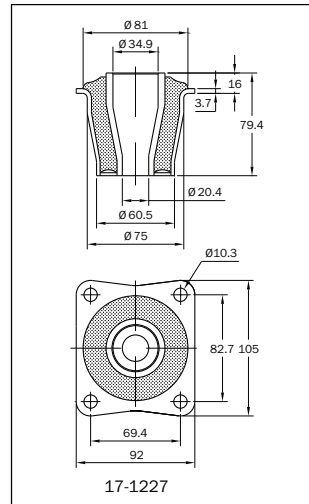
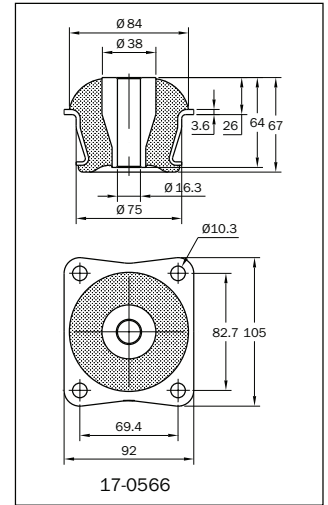
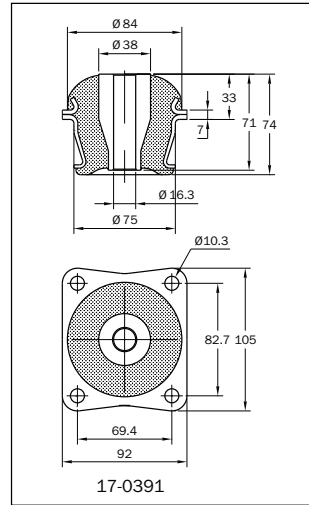

Drawing no. Metacone™	Top Washer Part no.	Bottom Washer Part no.
17-0189	20-00529	10-03666
17-0241	20-00529	10-03666
17-0248	20-00529	10-03666
10-0277	20-00773	20-00532
17-0379	20-00531	20-00531
17-0341	20-00773	20-00532
17-0311	20-00773	20-00532
17-1691	20-00535	20-00536
11-1009	20-00532	20-00532
17-0391	20-00532	20-00532
17-0566	20-00532	20-00532
17-1227	20-00528	10-03707
17-1550	20-02818	20-00534
17-1843	20-00533	20-00533
17-1865	20-00532	20-00532
17-0146	20-00527	10-03862
HK™		
HK60	20-01103	20-00416
HK600	20-00643	20-00644

Metacone™ & HK™

Note: The natural frequencies and degrees of isolation are based on dynamic characteristics of the mountings.

Load per mounting (kg)

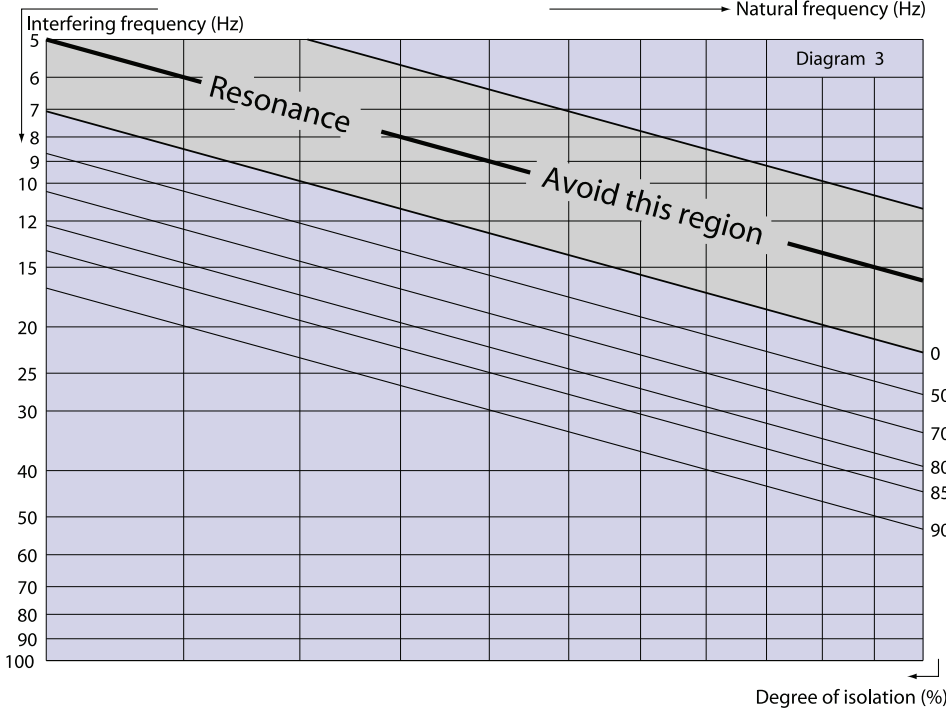
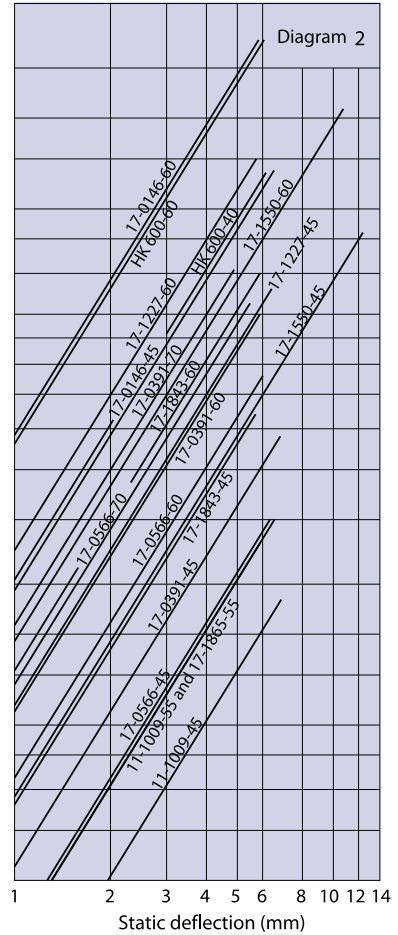
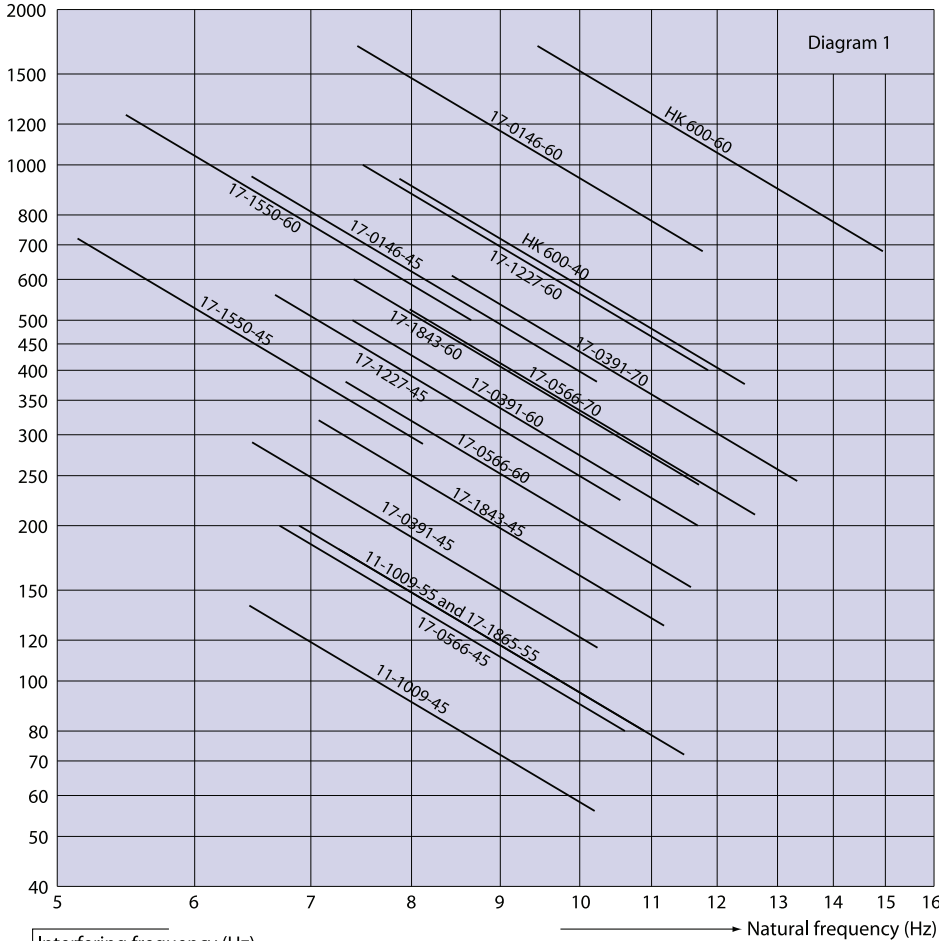

To select correct mounting, following data are needed:
 1) Load per mounting (kg)
 2) Interfering frequency (Hz)
 (Hz = rpm / 60)
 Select correct load line in diagram 1 and correct interference line in diagram 3. The load line intersects with required type of mounting.
 Connect this intersection point vertically down to the interference line in diagram 3. Here, on the sloping curve, the isolation degree is indicated.
 For static deflection, see diagram 2.

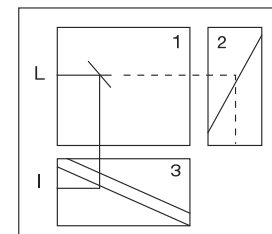

Metacone™ & HK™ Washer

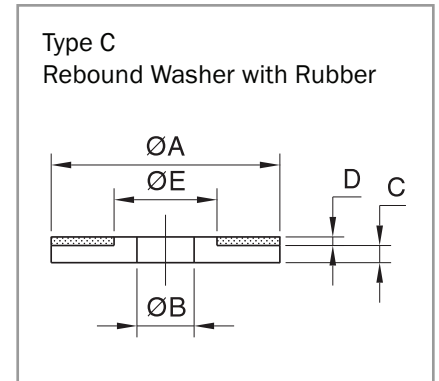
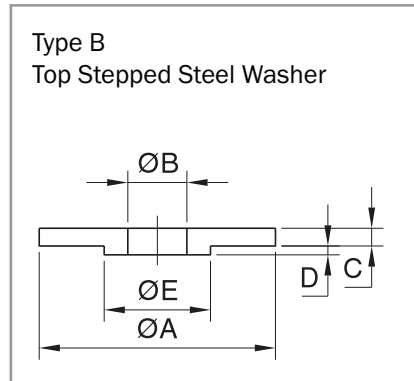
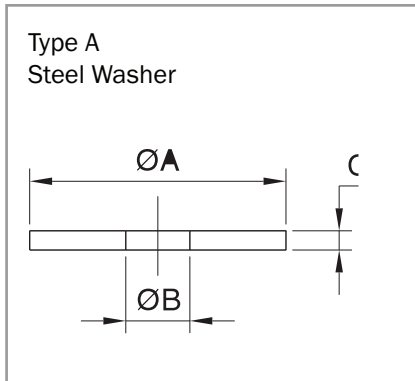

Recommended tightening torque for center fixing bolts	
Thread Size	Torque (Nm)
M10	25
M12	40
M16	60
M20	120
M24	200

Top and bottom washers

Overload and rebound washers (top and bottom) are necessary to limit maximum movement in the event of shock loading.

Designation	Drawing no.	Part no.	Model	Dimensions in mm				
				A	B	C	D	E
Washer 50*12C	15-0286	10-03666	C	50	12	3	3	28,5
Washer 95*24C	15-3526	10-03862	C	95	2,5	8	6	38
Washer 67,5*20C	15-3528	10-03707	C	67,5	20	5	5	30
Washer 116*24B	18-0146C	20-00527	B	116	24	8	4	47
Washer 80*20B	20-0562N	20-00528	B	80	20	6	3	34,5
Washer 55*12B	18-0241D	20-00529	B	55	12	5	2,5	25
Washer 80*16B	18-0311B	20-00773	B	80	16	6,5	3	31,5
Washer 50*10A	18-0379C	20-00531	A	50	10	4		
Washer 80*16A	18-0391C	20-00532	A	80	16	5		
Washer 100*20A	18-1101C	20-00533	A	100	20	6		
Washer 139*24A	18-1550C	20-02818	A	139	24	10		
Washer 55*12A	18-0472C	20-00535	A	55	12	5		
Washer 51*16A	18-0472D	20-00536	A	51	16	4		
Washer 57*12A	20-0562K	20-01103	B	57	16	3	1,5	22
Washer 52*12A	20-0562B	20-00416	A	52	16	3		
Washer 110*20B	20-0562C	20-00643	B	110	20	5	3	52,5
Washer 55*20A	20-0562D	20-00644	A	55	20	5		

Drawing no. Metacone™	Cone Mount	Top Washer Part no.	Bottom Washer Part no.
	17-0189	20-00529	10-03666
	17-0241	20-00529	10-03666
	17-0248	20-00529	10-03666
	10-0277	20-00773	20-00532
	17-0379	20-00531	20-00531
	17-0341	20-00773	20-00532
	17-0311	20-00773	20-00532
	17-1691	20-00535	20-00536
	11-1009	20-00532	20-00532

Drawing no. Metacone™	Cone Mount	Top Washer Part no.	Bottom Washer Part no.
	17-0391	20-00532	20-00532
	17-0566	20-00532	20-00532
	17-1227	20-00528	10-03707
	17-1550	20-02818	20-00534
	17-1843	20-00533	20-00533
	17-1865	20-00532	20-00532
	17-0146	20-00527	10-03862
HK™	HK60	20-01103	20-00416
	HK600	20-00643	20-00644